

DuraLine

MOTOR CORPORATION

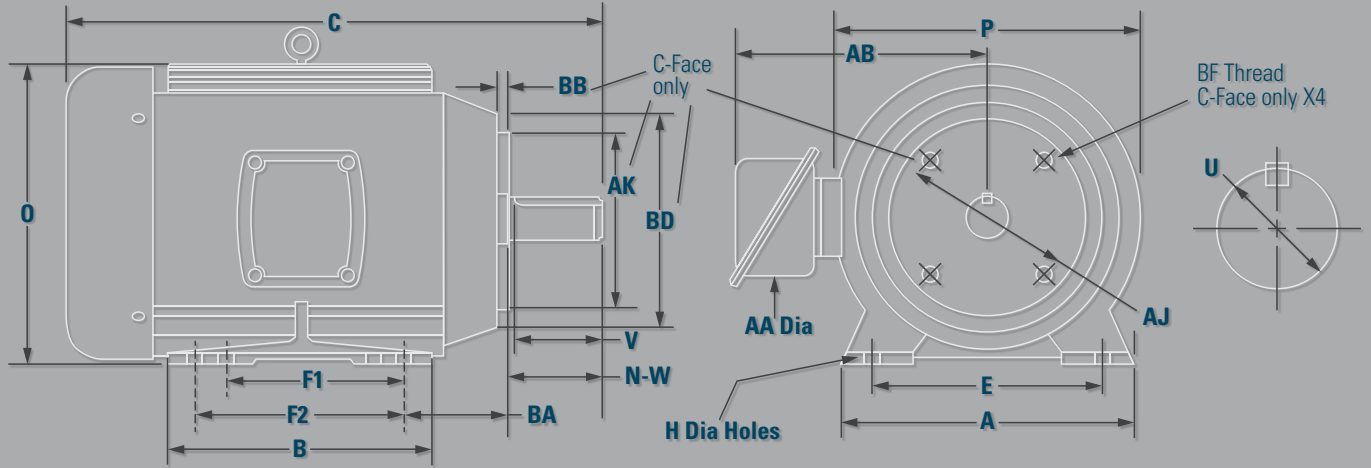

DIMENSIONS (inch)



Frame Size	A	B	D	E	F1	F2	H	N-W	O	P	AA	AB	AJ	AK	BA	BB	BD	V	BF	U	Key Width	Key Length	C	
143T	6 3/4	6	3 1/2	5 1/2	4	*	3/8	2 1/4	7	6 7/8	3/4	6	5 7/8	4 1/2	2 1/4	1/8	6 1/2	2 1/8	3/8-16	7/8	3/16	33/64	13	
145T					5	*	7/16																14	
182T	8 5/8	6 3/4	4 1/2	7 1/2	4 1/2	5 1/2	13/32	2 3/4	8 1/2	8 5/8	3/4	7 1/4	7 1/4	8 1/2	2 3/4	1/4	8 7/8	2 1/2	1/2-13	1 1/8	1/4	63/64	16 1/2	
184T																							16 1/2	
213T	10 1/2	8 5/8	5 1/4	8 1/2	5 1/2	*	13/32	3 3/8	10 1/4	11 5/8	1	8	7 1/4	8 1/2	3 1/2	1/4	9	3 1/8	1/2-13	1 3/8	5/16	1 13/64	18 3/4	
215T					7	*																	20 1/4	
245T	12 1/2	12	6 1/4	10	8 1/4	*	17/32	4	12 1/4	12 7/8	1 1/4	10	7 1/4	8 1/2	4 1/4	1/4	9 5/8	3 3/4	1/2-13	1 5/8	3/8	1 13/32	24	
256T					10	*																	25 3/4	
284T	14	12 1/2	7	11	9 1/2	*	17/32	4 5/8	13 3/4	14 1/8	1 1/2	11	9	10 1/2	4 3/4	1/4	11	4 3/8	1/2-13	1 7/8	1/2	1 19/32	27 1/4	
284TS						*																		3 1/4
286T					*	4 5/8	4 3/8	1 7/8	1/2	1 19/32	28 3/4													
286TS					*	3 1/4	3	1 5/8	3/8	1 13/32	27 1/2													
324T	16	14	8	12 1/2	10 1/2	12	21/32	5 1/4	15 3/4	15 5/8	2	13	11	12 1/2	5 1/4	1/4	13 3/8	3 1/2	5/8-11	2 1/8	1/2	1 19/32	31 1/4	
324TS																								5
326T		15 1/2																14		5 1/4		3 1/2	2 1/8	31 1/4
326TS																								
364T	18	15 1/2	9	14	11 1/4	*	21/32	5 7/8	17 3/4	17 9/16	3	14 1/8	11	12 1/2	5 7/8	1/4	14	5 5/8	5/8-11	2 3/8	5/8	2 3/16	33 1/2	
364TS																								3 1/2
365T		16 1/4		14	5 7/8	3 1/2	2 3/8	5/8	2 3/16	33 1/2														
365TS											3 1/2	1 7/8	1/2	1 19/32	31 1/4									
404T	20	16 1/4	10	16	12 1/4	13 3/4	13/16	7 1/4	20	19	3	15 1/4	11	12 1/2	6 5/8	1/4	15 1/2	3 1/8	5/8-11	2 7/8	3/4	2 29/64	38 1/4	
404TS																								2 25/32
405T		17 3/4						14										7 1/4		3 1/8	2 7/8	3/4	2 29/64	38 1/4
405TS																								
444T	22	18 1/2	11	18	14 1/2	16 1/2	13/16	8 1/2	21 3/4	21 9/16	3	18	14	16	7 1/2	1/4	18	8 1/4	5/8-11	2 3/8	5/8	2 3/16	44	
444TS																								4 1/2
445T		20 1/2						14										8 1/2		3 3/8	7/8	2 7/8	44	
445TS																								4 1/2
447T	22	22	11	18	20	25	13/16	8 1/2	21 3/4	22	3	18	14	16	7 1/2	1/4	18	8 1/4	5/8-11	3 3/8	7/8	2 7/8	40 1/4	
449T																								7/8

DURALINE PREMIUM EFFICIENT MOTORS

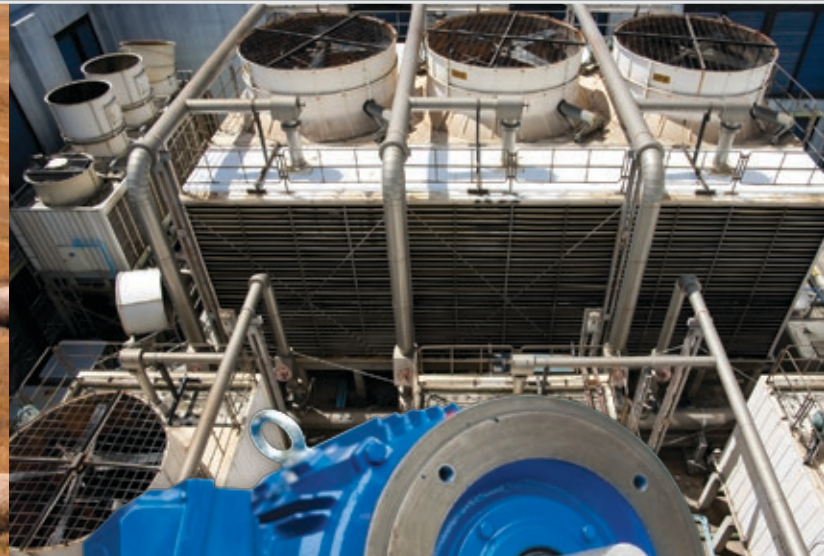

DURALINE MOTORS ARE TOUGH, DEPENDABLE PREMIUM EFFICIENT MOTORS.

Top Quality Certification

Duraline products are tested and certified by the finest quality and safety agencies ensuring that every Duraline motor will be a long lasting reliable workhorse for whatever application required.

Rugged High Temperature Insulation

Duraline motors are double vacuum impregnated with high temperature "H" class non-hygroscopic varnish. Our motors are fitted with spike resistant phase paper between each phase. This ensures inverter compatibility and long term reliability.

High Quality, High Durability Bearings

All our motors are equipped with the highest quality bearings for extremely long life and quiet operation. All of our bearings contain high carbon chrome steel rolling elements and premium lubricants. Our motors use oversized bearings on both the drive and the opposite drive end.

Peace of Mind Guarantee

If something does go wrong with your motor you are protected by our Top Guardian guarantee. If one of our motors fails due to workmanship or material failure, Duraline will repair your motor or ship you a replacement.

- 1-250HP TEFC Cast Iron 2,4 and 6 poles
- Inverter Rated 15:1 CT
- MG1 Part 31
- CSA Approved
- Nema Design B
- UL 1004 Approved
- 36 month Warranty
- 40° C Ambient Rating
- Stainless Steel Nameplates
- Corrosion Resistant Hardware
- F1, F2, F0 Convertible
- Class F Insulation
- Nipple Seals between Conduit Box and Body
- One-way Sintered Brass condensate drains
- Double Drilled Feet on 256T and up
- Removable Feet up to 326T
- 1.25 SF up to 365T/ 1.15 SF for larger frames
- V-Seal with Slinger on 254T and up
- 1045 Steel Shaft up to 326T/ 4140 Steel Shaft on 326T and up
- Regreasable Bearings on 254 frame and up
- Class 1 Division 2 Groups C and D Compliant

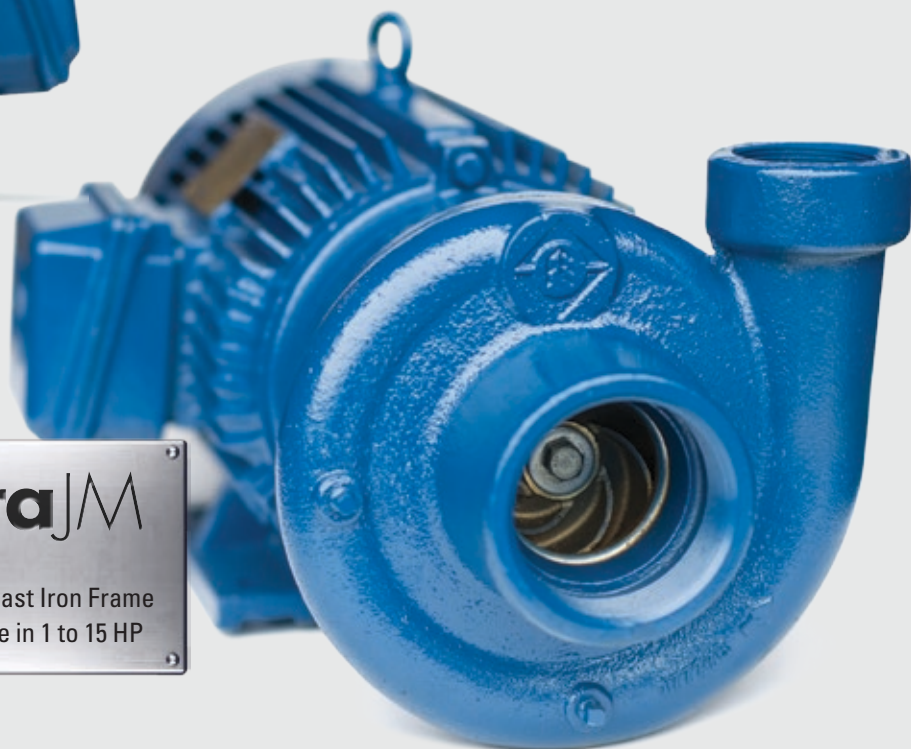
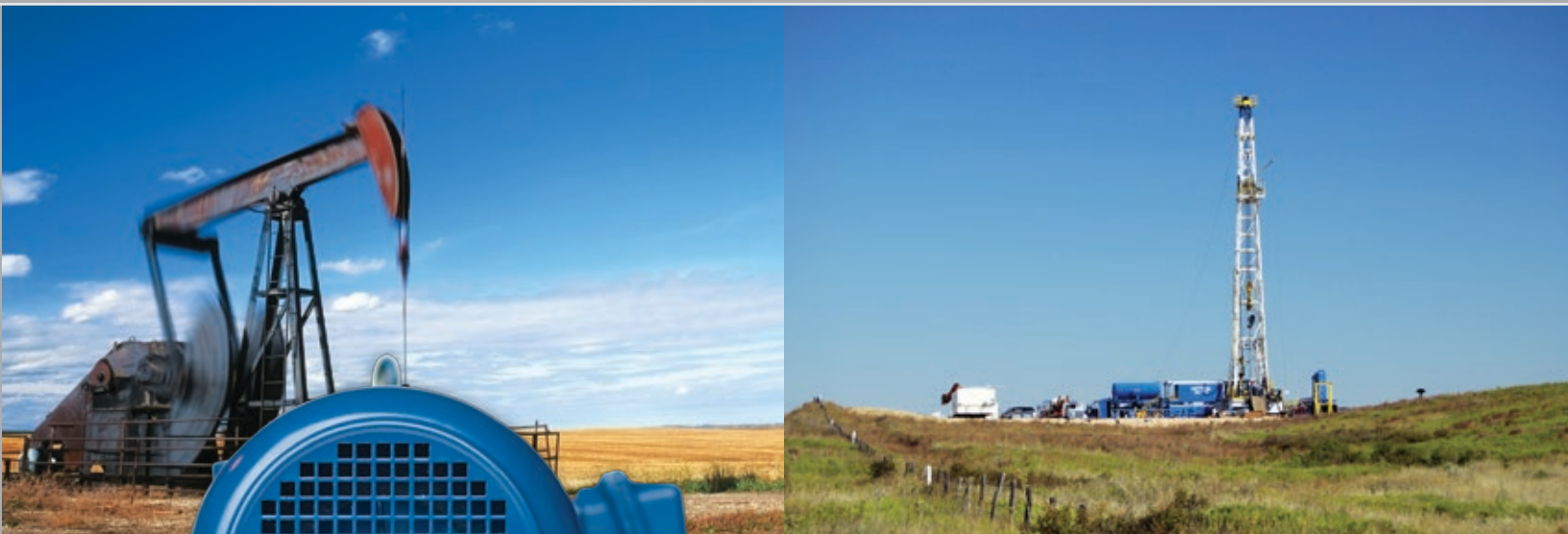

DURALINE WARRANTY

The 36 month warranty guarantees motors from defects of workmanship and materials when operating under normal conditions and in accordance with nameplate characteristics. This warranty shall be in effect for a period of thirty six months from date of installation but shall in no event be in effect for more than forty two months from date of sale.

Duraline Motor Corporation will repair or replace, at its option, any motor which is found to be defective and is within the warranty period, provided the motor is shipped with previous authorization to an authorized warranty service depot. Removal, installation and

any other expenses incurred in shipping the motor to and from the motor company is not included under the warranty.

Liability under this warranty shall be solely limited to repair or replacement of the motor within the warranty period and shall not be liable under any circumstances for incidental or consequential damages, including but not limited to personal injury or labour costs. Duraline Motor Corporation will in no way be responsible for expenses in connection with motor repairs made by a service station not authorized by the company in writing.



EDMONTON



Calgary Trail
Gateway Boulevard

104 Street
103 Street

Allendale Road

Mill Creek Ravine - South

Argyll Park

Hazeldean Park

DuraLine Motor Corporation

10003-69 Avenue, Edmonton, Alberta, T6E 0T1

Local: 780.433.4247

Toll Free: 1.800.667.2071

Fax: 780.439.4988

Email: sales@duralinemotors.com



51 Ave

51 Ave

51 Ave